

HIGHPOWER

SECURITY PRODUCTS



TEL: (203)-634-3900 FAX: (203)-238-2425
 HPSP@CONNIX.COM WWW.CONNIX.COM-HPSP

P/N 2000505
 P/N 2001505

POWER SUPPLY INSTRUCTION MANUAL

PHYSICAL FEATURES

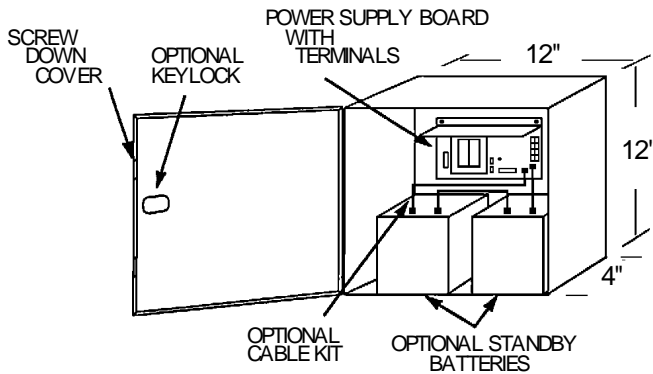

POWER SUPPLY DESCRIPTION

The Lightning 505 is a field selectable 12 / 24 VDC regulated power supply. When backup batteries are supplied, the Lightning 505 serves as an uninterruptable power supply, maintaining output power during power outages. With line power applied, a LED on the power supply circuit board will be illuminated. This LED indicates that output power is present at both the output and the standby battery terminals. When batteries used and no line power is present, the LED will also be illuminated, indicating that battery voltage is present at the output. The Lightning 505 has an automatic charging circuit that will maintain battery charge.

POWER SUPPLY BOARD FEATURES

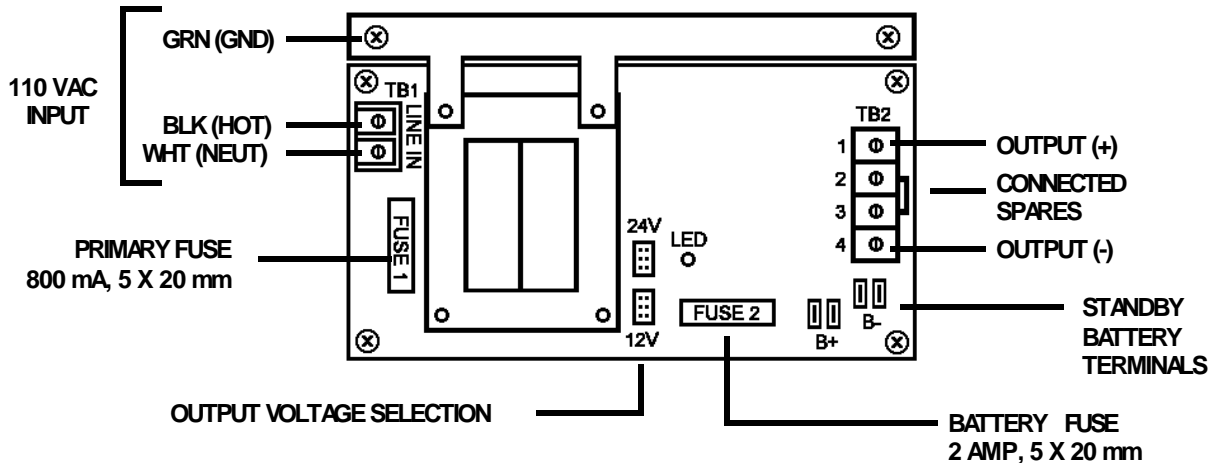

GENERAL SPECIFICATIONS

ELECTRICAL SPECIFICATIONS

INPUT POWER: 110 VAC, 60 Hz, 1/2 AMP (P/N 2000505)
 INPUT POWER: 220 VAC, 50/60 Hz, 1/4 AMP (P/N 2001505)
 OUTPUT VOLTAGE: Filtered, Regulated
 13.8 VDC or 27.6 VDC
 (Field Jumper Selectable)
 MAX OUTPUT CURRENT: 1 AMP
 CHARGING CIRCUIT: Built-in, standard.
 CHARGING TIME: Approx. 48 Hours from discharge.
 PRIMARY FUSE: 800 mA, 5 x 20mm
 BATTERY FUSE: 2 AMP, 5 x 20mm
 TYPICAL AMBIENT OPERATING
 TEMPERATURE: 72 F, 20 C
 SECONDARY PROTECTION: Voltage regulator
 has inherent overload protection and will
 shutdown in the event of overheating.

MECHANICAL SPECIFICATIONS

ENCLOSURE: 12 " x 12 x 4" Steel NEMA Grade 1
 with conduit knockouts and hinged
 cover with lockdown screws.
 WEIGHT (POWER SUPPLY): 8.0 lbs, 3.6 kg.
 WEIGHT (EACH BATTERY): Approx 4 lbs, 1.8 kg.
 INPUT TERMINALS: Barrier strip with (2) #6
 screw terminals.
 OUTPUT TERMINALS: Barrier strip with
 (4) #6 screw terminals and
 (4) quick connect terminals.

OPTIONS AVAILABLE

Standby Battery (P/N 2010505)
 Cable Kit (P/N 2020505)
 Enclosure Cover Key Lock (P/N 2030505)
 AC Power Line Chord, 6 foot (P/N 2040505)

THIS POWER SUPPLY IS INTENDED FOR USE IN A CONTROLLED ENVIRONMENT.

SAFETY CONSIDERATIONS

For safety, please read all supplied documents before installing.

CAUTION: Use extreme care when performing installation procedures, as high voltage line power is present on certain terminals. All high voltage installation and service must be performed by qualified electricians.

If your unit was shipped with the Standby Battery Pack option, refer to the instructions to ensure that the correct wiring configuration has been made for your selected operating voltage.

When replacing fuses, ensure that the electrical problem is first resolved. Use only similarly rated replacement fuses.

If you are having problems with any installation step, we want to know about it! Don't hesitate to call your supplier or Highpower for assistance in installing this power supply.

INSTALLATION: MOUNTING ENCLOSURE

STEP 1: Mounting holes are provided in the back surface of the enclosure. Firmly secure the enclosure to a solid surface with a minimum size of #8 mounting hardware. Check national and local codes for installation requirements.

INSTALLATION: OUTPUT VOLTAGE SELECTION

STEP 2: Verify or change the output voltage jumper to the desired output voltage.

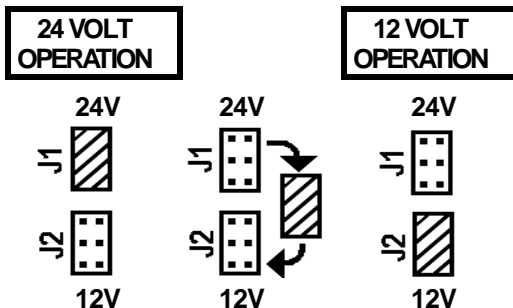

INSTALLATION: INPUT POWER CONNECTION

STEP 3: Connect input power leads.

Before wiring line power to power supply board, check to ensure that this procedure is in compliance with local codes regarding high voltage connections.

CAUTION: Check to make sure that no power is present on the input leads before making any connections.

Wire VAC line to terminal block 1 (TB1) as shown:

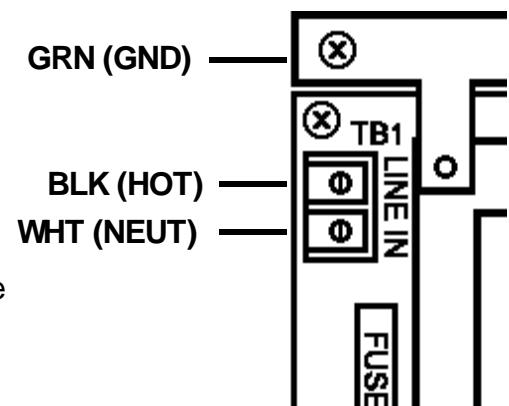

INSTALLATION: OUTPUT SYSTEM CONNECTION

STEP 4: Make all output system wiring connections to terminal block 2 (TB2). Pages 3 and 4 show typical wiring arrangements.

NOTE: All low voltage wiring to be minimum 18 AWG stranded multi-conductor color coded wire without splices. A minimum of two (2) spare conductors is recommended. Wiring to conform to applicable national, state and local electrical codes for class 2 fire protection signaling and control devices.

SYSTEM WIRING INFORMATION

TERMINAL BLOCK 2 (TB2)

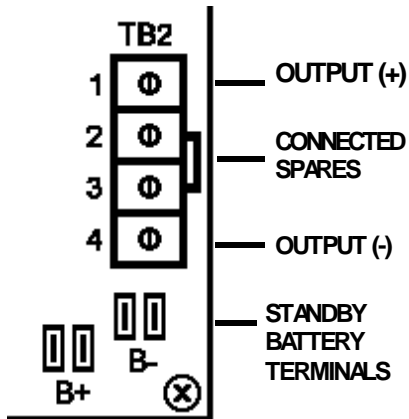

		WIRE SIZE SELECTION							
TOTAL ONE-WAY LENGTH OF WIRE RUN	LOAD CURRENT @ 24 V				LOAD CURRENT @ 12 V				
	1/4A	1/2A	3/4A	1A	1/4A	1/2A	3/4A	1A	
100 ft. (30 m)	24	20	18	18	20	18	16	14	
150 ft. (45 m)	22	18	16	16	18	16	14	12	
200 ft. (60 m)	20	18	16	14	16	14	12	12	
250 ft. (80 m)	18	16	14	14	16	14	12	10	
300 ft. (90 m)	18	16	14	12	16	12	12	10	
400 ft. (120 m)	18	14	12	12	14	12	10		
500 ft. (150 m)	16	14	12	10	14	10	10		

NOTES: External controls and switches must have contacts rated to handle the total load being switched. Note that the maximum load of this power supply is 1 Amp @ 27.6 VDC. For safety, use switches with contacts rated at 120 VAC, 3 AMP / 30 VDC 3 AMP or better.

It is recommended that hook-up wire be 18 AWG minimum. Actual wire size calculations should be based on total length of wire run from power supply to locking device. Wire size should allow no more than 5% voltage drop over wire run.

Controls (i.e. pushbutton switches, key switches, card readers and other contacts) should be wired as followed:

Fail-safe locks: Require normally closed contacts. Multiple contacts are wired in series.

Fail-secure locks: Require normally open contacts. Multiple contacts are wired in parallel.

NOTES

HOW CAN WE IMPROVE OUR PRODUCTS ?
TELL US WHATS ON YOUR MIND !

PHONE US AT: (203)-634-3900
OR EMAIL US: HPSP@CONNIX.COM

LOCK SYSTEM WIRING DIAGRAMS

FAIL-SECURE LOCKS (OPEN CONTROL CONTACTS)

FIGURE A

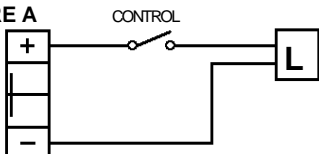

- * SINGLE LOCK
- * SINGLE CONTROL
- * Control wired along lock power line - Least amount of conductors in wire run.

FIGURE B

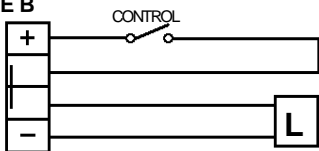

- * SINGLE LOCK
- * SINGLE CONTROL
- * Each component wired back to power supply - provides a common junction box for convenient hook-up and troubleshooting.

FIGURE C

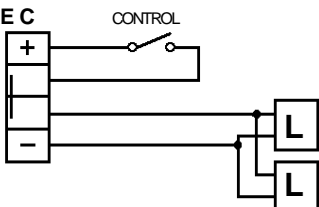

- * DOUBLE LOCK OR MULTIPLE SINGLE LOCKS
- * SINGLE CONTROL
- * Locks wired in parallel in vicinity of locks.

FIGURE D

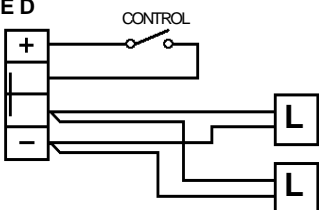

- * DOUBLE LOCK OR MULTIPLE SINGLE LOCKS
- * SINGLE CONTROL
- * Separate wire runs for each lock - reduces voltage drop and wire size for long wire runs.

FIGURE E

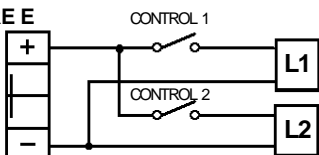

- * MULTIPLE SINGLE LOCKS
- * Individual control for each lock.

MONITORING SYSTEM WIRING

FIGURE F

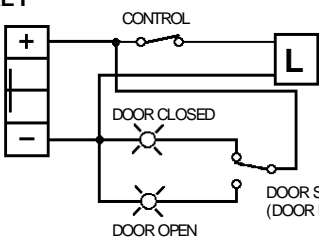

DOOR STATUS

FIGURE G

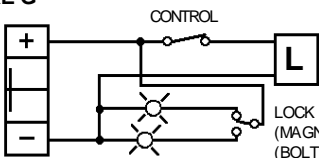

LOCK STATUS

FIGURE H

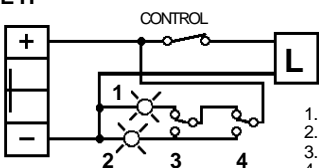

DOOR & LOCK STATUS

1. DOOR CLOSED & LOCKED
2. DOOR OPEN OR UNLOCKED
3. DOOR STATUS SWITCH
4. LOCK STATUS SWITCH

FAIL-SAFE LOCKS (CLOSED CONTROL CONTACTS)

FIGURE I

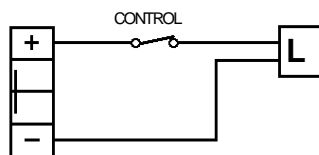

- * SINGLE LOCK
- * SINGLE CONTROL
- * Control wired along lock power line - Least amount of conductors in wire run.

FIGURE J

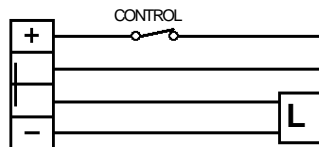

- * SINGLE LOCK
- * SINGLE CONTROL
- * Each component wired back to power supply - provides a common junction box for convenient hook-up and troubleshooting.

FIGURE K

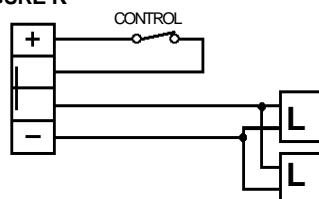

- * DOUBLE LOCK OR MULTIPLE SINGLE LOCKS
- * SINGLE CONTROL
- * Locks wired in parallel in vicinity of locks.

FIGURE L

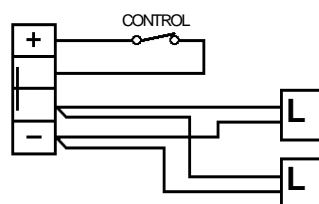

- * DOUBLE LOCK OR MULTIPLE SINGLE LOCKS
- * SINGLE CONTROL
- * Separate wire runs for each lock - reduces voltage drop and wire size for long wire runs.

FIGURE M

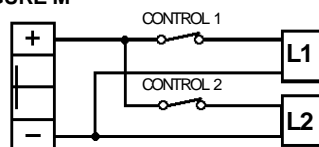

- * MULTIPLE SINGLE LOCKS
- * Individual control for each lock.

FIGURE N

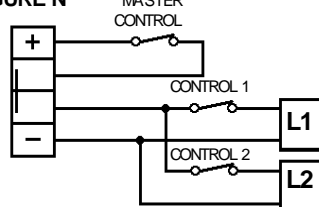

- * MULTIPLE SINGLE LOCKS
- * Individual control for each lock with Master Control for both locks. May be master emergency switch, fire panel, etc.

FIGURE O

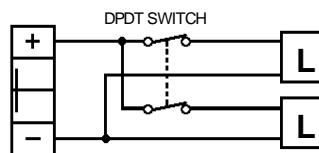

DPDT Control Switch for simultaneous release of two locks without "release delay".

Occasionally, two magnetic locks released by one contact will exhibit a delay in the release of one of the locks. If this condition is perceived as a problem, a DPDT switch should be used to eliminate the delay.

TEST INSTALLATION

STEP 5: With line power present, the LED on the power supply circuit board should illuminate. This indicates that low voltage power is present on terminal block 2 (TB2), terminals 1 and 4. Locking system should operate according to selected system wiring diagram. If problems occur, check the "POWER SUPPLY TROUBLESHOOTING" section, page 6.

STANDBY POWER OPTIONS

Standby batteries are supplied and packaged separately. For 12 volt operation, one or two batteries may be used. For 24 volt operation, two batteries in series are required. Since many electromagnetic locks draw twice as much current in 12 volt operation as compared to 24 volt operation, we recommend using two parallel batteries in the 12 volt operating mode. This will provide suitable backup time during power failure.

- (1) Standby Battery (12 V 4Ah rechargeable sealed lead acid.) (P/N 2010505)
- (1) Battery Cable Kit (12 or 24 volt installation) (P/N 2020505)

4 AMP/HOUR OUTPUT	
STANDBY TIME HOURS	SYSTEM CURRENT DRAW (AMPS) (12 OR 24 VOLT)
3	1.00
6	.50
8	.45
12	.33
18	.22
24	.16
36	.11
48	.09

INSTALLATION: STANDBY BATTERIES

- STEP 6:** Turn off 110 VAC line power to the power supply.
- STEP 7:** Set batteries upright in bottom of power supply enclosure.
- STEP 8:** Using the cable kit, ensure that the correct wiring configuration is used for the selected output voltage set in step 2.

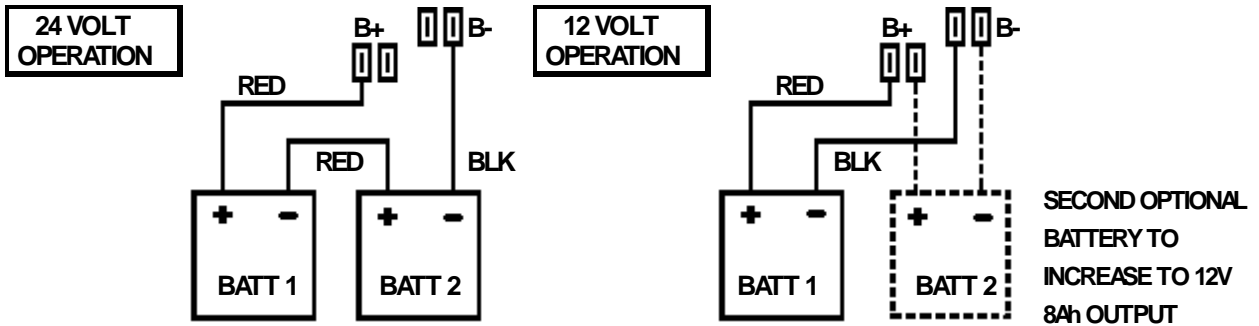

CAUTION: Remember to observe the battery polarity! Improper battery connection could cause personal injury or damage to power supply components.

BATTERY TESTS

With 110 VAC line voltage applied, the power supply recharging circuit can be checked for proper operation. Using a voltmeter, measure the output voltage at the battery quick connect terminals. Meter reading, without batteries connected should be:

- Approx. 13.8 VDC for 12 Volt operation*
- Approx. 27.6 VDC for 24 Volt operation*

After 48 hours, the backup system can be checked. Temporarily shut off the 110 VAC power to the power supply. Locking system should operate normally. If not check your wiring and look at the "Power Supply Troubleshooting" section.

Highpower can only ensure proper performance with batteries supplied from our factory.

POWER SUPPLY TROUBLESHOOTING

NOTE: The power supply may run hot under full load. This condition is normal. Due to improved heat-sinking design, the Lightning 505 often runs cooler than other competitors models.

FUSE PROBLEMS

Whenever a fuse has blown, an attempt should be made to identify any electrical problems that caused it's failure. Correct this problem before replacing the fuse. Use only similarly rated and sized fuses as fuses with ratings other than those specified may damage the unit and prove hazardous. Do not jump fuses or prevent the proper operation of a fuse.

PRIMARY FUSE: Caused by poor line power, damaged circuit board, damaged transformer or damaged component on board.

BATTERY FUSE: (a) Incorrect battery connections. Check your wiring and cable kit leads.
 (b) Excessive load on output. Reduce load; use a second supply.
 (c) Direct short on output. Check the wiring of the output system

PROBLEMS (WITH LINE POWER PRESENT)

PROBLEM	POSSIBLE CAUSE	ACTION TO TAKE
No output power (LED not illuminated).	No line power. Blown primary fuse. Voltage selection jumper missing.	Check & provide line power. Replace fuse (see FUSE PROBLEMS, above). Replace jumper on terminals.
Improper output voltage.	Voltage selection jumper in wrong position.	Move jumper position (see INSTALLATION: OUTPUT VOLTAGE SELECTION section, page 2)
Lock not working. (LED is illuminated)	Improper output system hook-up.	Check wiring diagrams & output system wiring.
Lock or output circuit works erratically. Lock holding force is weak.	Improper output voltage selection. Low output voltage due to excessive load. Low voltage at lock due to insufficient hook-up wire size.	Check output, move voltage selections jumper. Reduce load. Increase hook-up wire size.
Line power is present and fuses are ok, but no output power.	Voltage regulator automatic thermal overload shutdown.	Reduce load. Ensure that load does not exceed 1 Amp at rated voltage. Maintain ambient temperature to specifications.

PROBLEMS (WITHOUT LINE POWER)

No output power. (LED not illuminated)	Batteries not connected. Blown battery fuse.	Check & correct battery hookup. Replace fuse (see FUSE PROBLEMS, above).
Lock or output not working or erratic (LED may be dim).	Weak batteries. Incorrect battery hookup. Wrong voltage selection.	Restore primary power & allow batteries to charge. Check & correct battery hookup and voltage selection jumper. Replace battery.
Low output voltage.	Excessive load. Old or damaged batteries.	Reduce load. Check charging circuit voltage (see BATTERY TESTS section, page 5).

FIRE SYSTEM INTERFACING

In some installations, it may be required by code that the locking device (fail-safe type) be immediately unlocked upon actuation of an approved fire emergency system. Whenever this type of installation is required, check with the Authority Having Jurisdiction for approval of the proposed system hook-up.

A normally closed, dry contact from the fire system may be wired in series with the lock control contact(s) in order to release the lock when the fire system is activated.

Suggested wiring for single or multiple lock systems are shown. For safety and reliability, the fire panel contact must be rated to handle the total current load being switched. The maximum load of the Lightning 505 is 1.0 Amps at 27.6 VDC.

The wire size from the fire system contact to the power supply is determined by the distance of the wire run. The wire size should allow no more than a 5% voltage drop. See the "WIRE SIZE SELECTION CHART" in the "SYSTEM WIRING INFORMATION" section, page 3.

WARNING:

The items listed in the manual may require the services of an individual who is trained in the application and installation of life safety equipment. All wiring must be in compliance with current NEC guidelines.

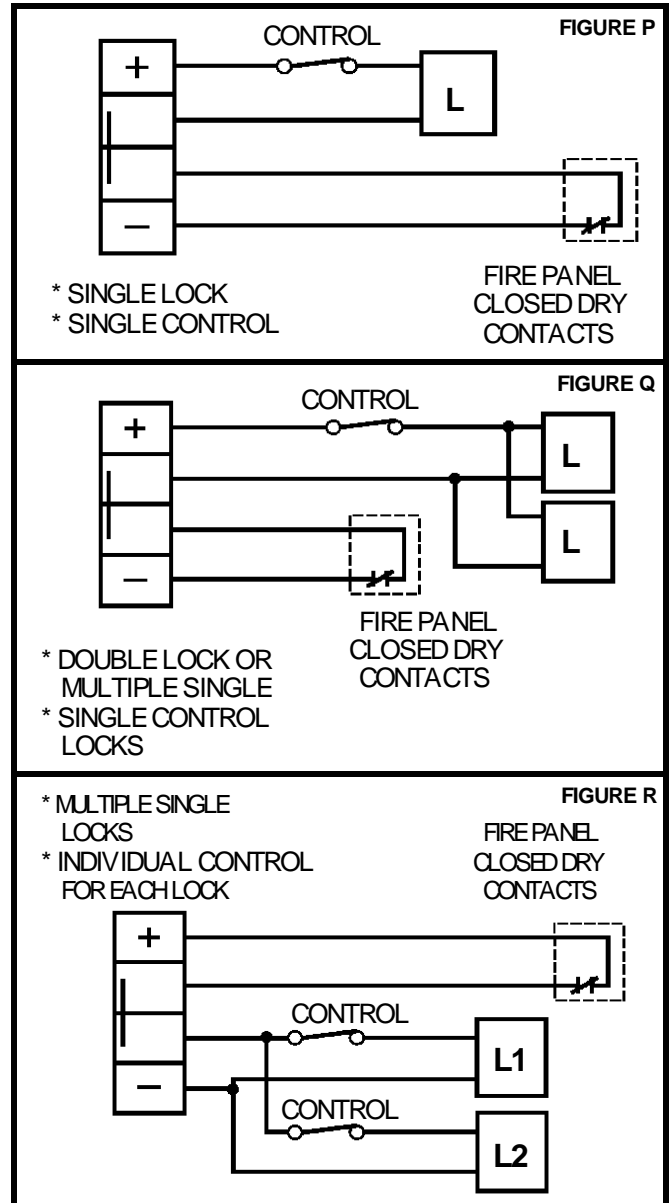

WARRANTY

THANK YOU FOR CHOOSING HIGHPOWER!

The Highpower Security Products, LLC Lightning 505 Power Supplies are manufactured to the highest quality standards to provide years of dependable service. The Lightning 505 is warranted for two years from date of shipment against defects in parts, workmanship and materials, when installed in accordance with instructions. Defects which occur within this warranty period, under normal use of the product, shall be repaired or replaced with a new unit, solely at our option. Warranty is void when product has been modified, damaged, abused, misused, subjected to abnormal use or neglect, or subjected to harsh operating environment out of the normal operating specifications.

No agent, employee or representative of Highpower Security Products, LLC has authority to bind Highpower Security Products, LLC to any oral affirmation, representation or warranty, other than set forth above.

Highpower Security Products, LLC expressly disclaims all other warranties, expressed or implied, including but not limited to any implied warranties of merchantability or fitness for a particular purpose. "Fail-Safe" and "Fail-Secure" are definitions only. Use of these terms is not a performance warranty, but merely a descriptive term used to characterize a design feature.

HIGHPOWER
SECURITY PRODUCTS

290 Pratt Street, 4th Floor, - Meriden, CT 06450

Tel: (203) 634-3900 - Fax: (203) 238-2425

Web: WWW.CONNIX.COM/~HPSP

Email: HPSP@CONNIX.COM

THANK YOU FOR CHOOSING HIGHPOWER !